



BAGSAN





BAGSAN

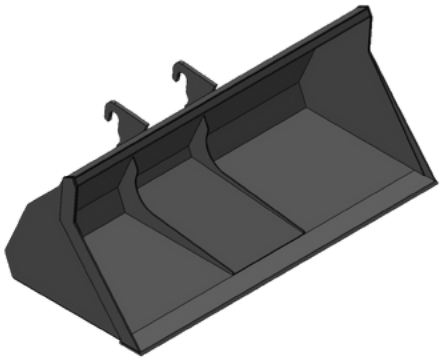

STANDART BUCKET

Ideal for general-purpose material handling, suitable for a variety of construction and landscaping tasks.

Width: 2340 mm **Volume:** 1,1 m³

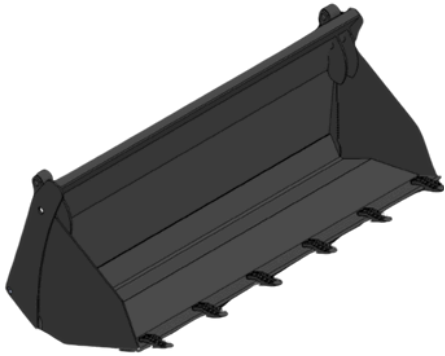

OPENING BUCKET LARGE

Designed for efficient material handling with a wide opening mechanism, making it ideal for tasks that require quick loading and unloading.

Width: 2340 mm **Volume:** 1 m³

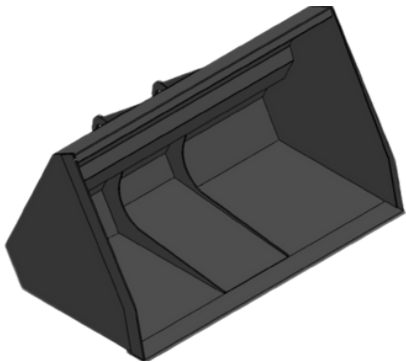

GRAIN BUCKET

Specifically designed for handling grain and other bulk materials.

Width: 2340 mm **Volume:** 2,2 m³

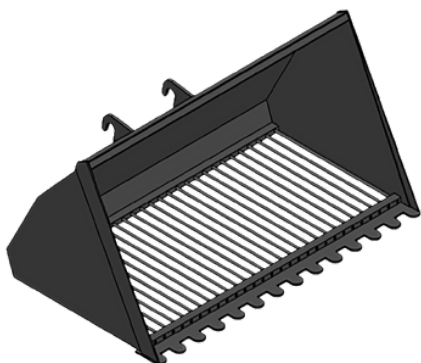

BEET BUCKET

Engineered for the efficient handling and transport of beets and similar root crops.

Width: 2340 mm **Volume:** 2,2 m³

ATTACHMENTS

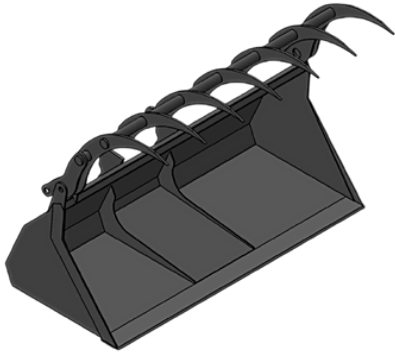

GRAPPLE BUCKET

Ideal for handling irregularly shaped materials like logs, branches, and debris.

Width: 2340 mm **Volume:** 1,1 m³

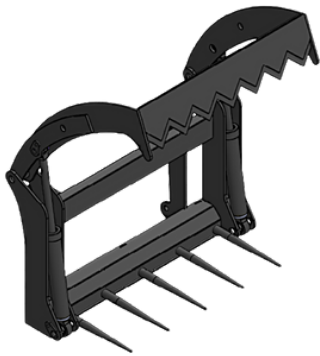

SILAGE CUTTING FORK

Designed for efficient handling and precise cutting of silage bales.

Capacity: Capable of gripping and cutting silage bales of 500 kg and 1000 kg.



LOG GRAPPLE FORK

Specially designed for gripping and transporting logs and large timber.

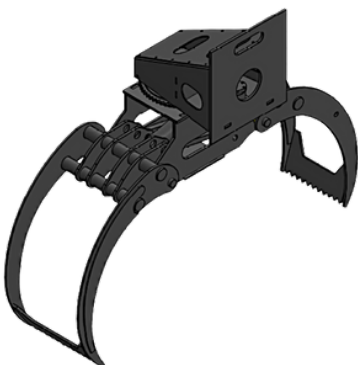

LOG GRAPPLE 360°

Designed for versatile and precise handling of logs and timber, the 360° rotation allows for efficient operation in tight spaces.



BAGSAN

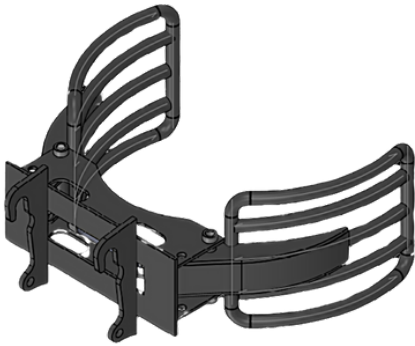

ROLL BALE HANDLING

Perfect for handling and transporting round bales efficiently.



BALE SKEWER 3 FORK

Designed for efficient and stable transportation of hay, straw, and silage bales.

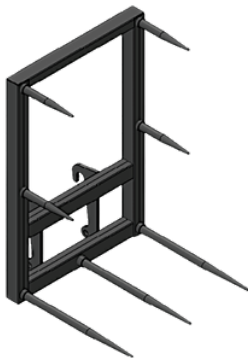

BALE SKEWER 7 FORK

Optimized for secure and efficient handling of bales in agricultural settings. Features 3 main skewers plus 4 auxiliary mini skewers for enhanced stability.

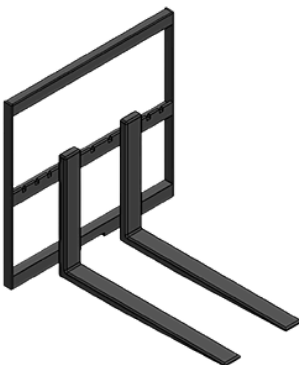

PALLET FORK

Manually set the forks to your desired width for efficient lifting, transporting, and stacking in various industrial and agricultural environments.

ATTACHMENTS

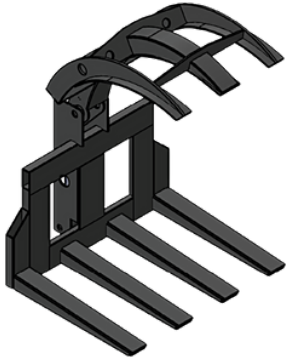

RECYCLING MATERIAL HANDLING

Ideal for sorting, lifting, and transporting various recycling loads in waste management and recycling facilities.

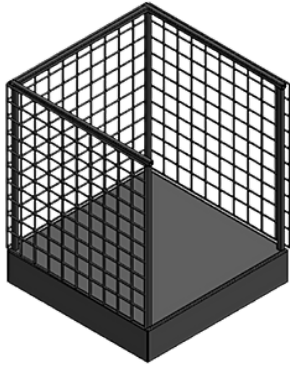

PLATFORM BASKET SMALL

A compact, single-person basket with a 1 square meter platform for safe access to elevated areas. Ideal for tight spaces.

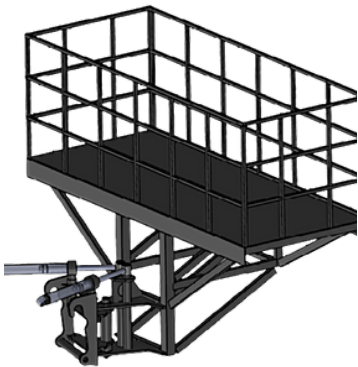

PLATFORM BASKET LARGE

With a length of 1 meter and a width of 3 meters, the platform offers a large footprint for multiple tasks and increased stability in high working environments.

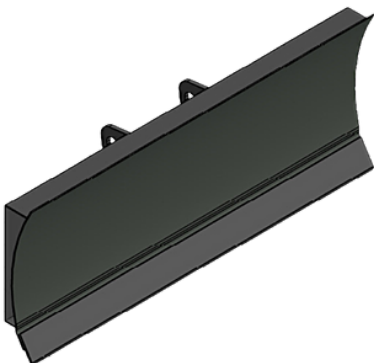

LEVELING SHOVEL

A versatile shovel for precise leveling and grading of surfaces, suitable for construction, landscaping, agriculture, and livestock tasks.



BAGSAN

